

# PROCO SPIN TRIMMER

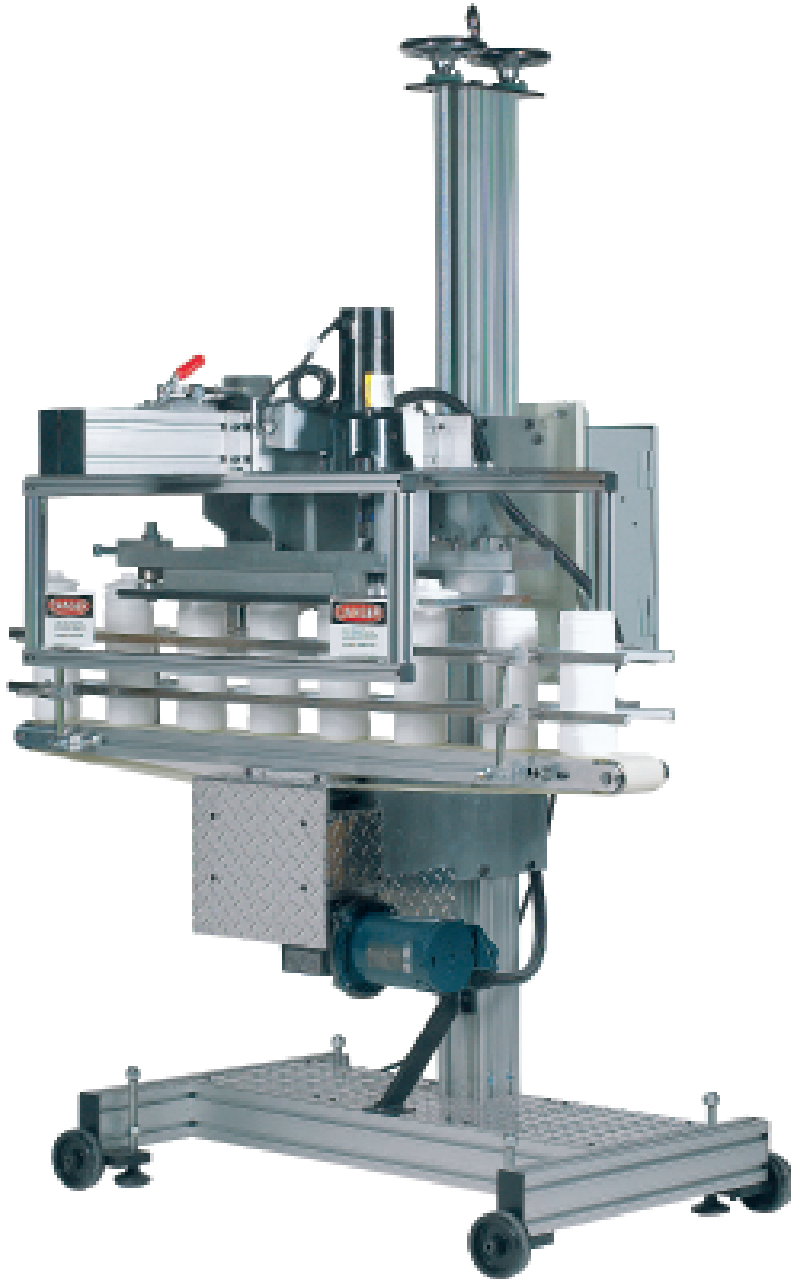

## Innovative Flexible Design

The Blow Molding Industry selects Proco equipment because it is reliable, enhances efficiency and improves quality. Why should you settle for less?

The Proco Spin Trimmer has been designed using the same innovative techniques which have led to the tremendous success of other Proco down-stream equipment such as Robotic Take-Outs, Deflashers, Flame Treaters, and Leaktesters. The unique design of this new-style Spin Trimmer provides a flexibility that is not normally available, and is adaptable to virtually any spin dome style. Special features provide greater control, off-the-shelf knife blades and blade heaters are standard and, most importantly, provides a neck finish that is the highest standard possible.

## PRODUCT FEATURES

### Drive Belt

The Proco drive belt provide much greater control over the linear feed of the container as it passes through the trimmer. This additional control results in a cleaner cut and a smoother neck surface on the finished container.

### Flexibility

Flexible design allows the trimmer to be adapted to virtually any spin dome style that you are currently using. Send us the details of your design so that we can factory equip our Spin Trimmer to match. Change parts can also be supplied as required for re-tooling in the field; this is a particular benefit to custom blow molders.

### Quick-Change Blades

The quick-change knife blade holder can be quickly exchanged for another holder with a new blade pre-installed, reducing down-time and ensuring the highest quality finish possible.

### Standard Blades

Standard knife blades can be inexpensively purchased from Proco or your local supplier, ensuring that a supply of sharp blades are always available. Dull blades are disposable, as the low cost per blade is less than the cost to re-sharpen.



*Blow Molding Automation*

# PROCO SPIN TRIMMER

## Convenient Features

The Proco Spin Trimmer is equipped with standard conveniences such as hand-wheel height adjustment of both the Spin Trimmer mechanism and the optional product conveyor. These features, together with the easily adjustable guide rails, ensure that change-over from one container size to another is achieved with minimum effort and within a short period of time. Proco Spin Trimmers are built on the same sturdy state-of-the-art structural aluminum frame system that forms the common platform for other Proco products. This ensures compatibility with additional Proco downstream equipment.

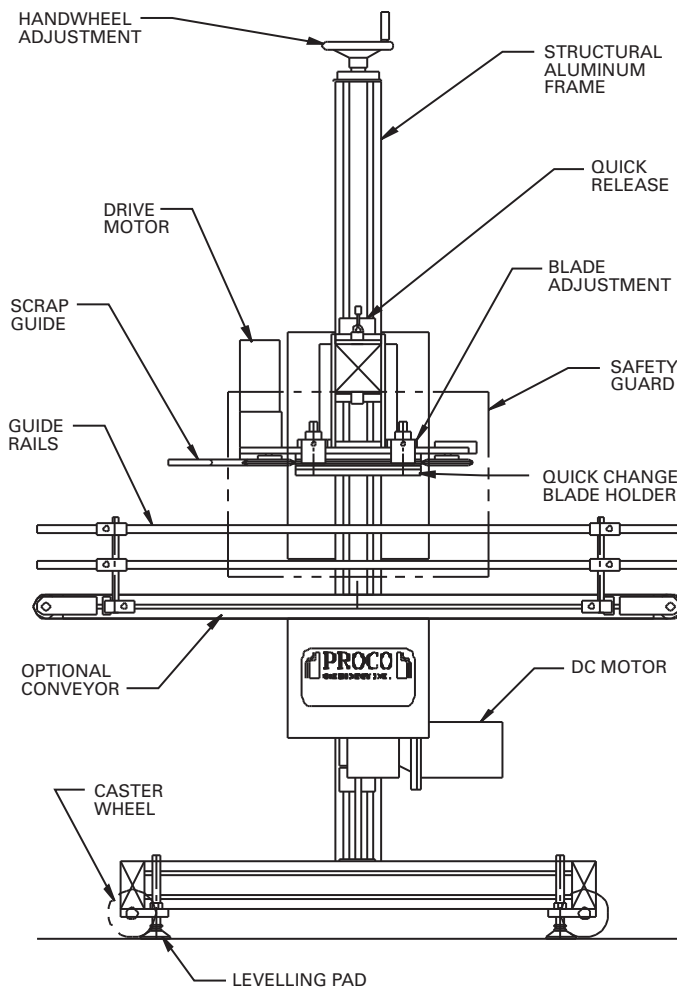

## Built In Quality

As with all Proco products the Spin Trimmer has been manufactured to the highest engineering standards. It is tough and rugged enough for the harshest of environments. Choose the Proco Spin Trimmer for your next wide mouth container project and experience the benefits of a quality finish that is unsurpassed within the industry.

## PRODUCT FEATURES

### Hand wheel Adjustments

Hand wheel adjustments on both the Spin Trimmer mechanism and the optional product conveyor make adjustment and set-up by a single operator both convenient and efficient.

### Caster Wheels

Caster wheels enable portability. The unit can be moved quickly and easily from one location to another within your production area. Leveling pads ensure stability during production.

### Structural Frame

The state of the art structural aluminum frame system provides flexibility in design and adjustment. It is compatible with other Proco products and the high tech look enhances the overall appearance of your production facility.

### Safety Guards

The Proco Spin Trimmer is equipped with safety guards around the moving parts and blade area. A quick release mechanism makes it both simple and safe to release containers in the event of a jam.



*Blow Molding Automation*

310 Annagem Blvd., Mississauga, Ontario, Canada L5T 2V5

Tel: 905-670-9380 Fax: 905-670-9382

[www.procomachinery.com](http://www.procomachinery.com)